



भारत 2023 INDIA

ADMINISTRATIVE NOTE

Startup20 Inception Meeting

Hyderabad, 28th and 29th Jan 2023

वसुधैव कुटुम्बकम्

ONE EARTH • ONE FAMILY • ONE FUTURE

Table of Contents

1. INTRODUCTION	3
2. PROVISIONAL AGENDA	6
Main Event Dates, Venue and Program	8-9
3. ACCREDITATION OF PARTICIPANTS	10
Delegation Contact Officer (DCO)	11
Delegation Liaison Officer (DLO)	11
4. MEDIA & COMMUNICATION	12
5. VISA REQUIREMENT	14
6. HEALTH REQUIREMENTS	16
7. MEETING VENUE	19
8. ACCOMMODATION	23
9. FLIGHT INFORMATION, IMMIGRATION, AIRPORT TRANSFER & CUSTOMS	27
10. EXCURSION	30
11. PERSONAL INFORMATION	33
12. GENERAL INFORMATION	35
13. IMPORTANT DATES	39



वशुधैव कुदुम्बकम् | ONE EARTH • ONE FAMILY • ONE FUTURE

1. INTRODUCTION

वशुधैव कुदुम्बकम्

ONE EARTH • ONE FAMILY • ONE FUTURE



The Indian G20 Presidency warmly welcomes all the delegates to the Startup20 Inception Meeting of G20 which will take place in-person in the city of Hyderabad (Telangana), on 28th & 29th January 2023. Hyderabad city is a metropolitan city with a population of nearly 12 million and is popularly known as City of Pearls. It is an ancient city established more than 400 years ago, known for its IT Industry and Hub for Pharma Sector. Musi river is the landmark of Hyderabad city which cuts Hyderabad city into two parts, as Old City and New City. Hussain Sagar lake is another landmark. Mecca Masjid, Chowmahalla Palace, Falaknuma Palace, Ramoji Film City, Hussain Sagar Lake, Birla Mandir, Qutub Shahi Tombs, Salarjung Museum, Tank Bund are major tourism attractions of Hyderabad City.

The Administrative Circular intends to provide delegates and participants with information pertaining to the administrative and logistical arrangements, as well as other general information regarding Startup20. Delegates will be notified via email of any changes in the programme elements or any other updated/additional information.

Information within this Administrative Circular is current as of 21st December 2022. The secretariat will notify delegates via email should there be any changes. For further inquiries and assistance, delegates, participants, and Diplomatic Mission representatives may contact the Indian G20 Secretariat by writing to:

- For substantive issues: chair-startup20@nic.in or startup20.g20@investindia.org.in
- For logistics issues: g20.logistics@gov.in



2. PROVISIONAL AGENDA

वशुधैव कुटुम्बकम्

ONE EARTH • ONE FAMILY • ONE FUTURE

Main Event Dates: 28th & 29th January 2023

Main Event Venue

- Hotel Taj Krishna

Day 1: Friday, 27th January 2023	
Time	Program
8:00 Hrs onwards	Arrival of delegates and Check-in
18:00 to 21:00 Hrs	Ice-breaker session and Welcome Reception <i>At Taj Krishna Palace (Gardenia)</i>
21:00 Hrs onwards	Delegates depart to their respective hotels

Day 2: Saturday, 28th January 2023	
Time	Program
6:30 Hrs onwards	Breakfast at respective hotels
8:00 to 8:30 Hrs	Delegates arrive at the Taj Krishna Palace
8:30 to 9:00 Hrs	Registration of Participants at Taj Krishna Palace <i>At the Grand Ball Room</i>
9:00 to 10:00 Hrs	Inaugural Session <i>At the Grand Ball Room</i>
10:00 to 10:30 Hrs	Tea / Coffee Break <i>At the Grand Ball Room (pre function area)</i>
10:30 to 11:30 Hrs	Plenary Session I: Introduction & Context Setting on Task Forces of Startup20 <i>At the Grand Ball Room</i>
11:30 to 12:00 Hrs	Plenary Session II: Introduction of Chairs & Co-Chairs of the Task Forces
12:00 to 13:30 Hrs	Moderated Open Discussion
13:30 to 14:30 Hrs	Networking Lunch <i>At the GBR Lawns</i>
14:30 to 14:45 Hrs	Gathering at main lobby for departure for Innovation Immersion Tour
15:45 to 19:00 Hrs	Innovation Immersion into the Startup Ecosystem: Hyderabad Chapter (16:00–19:00 Hrs)
19:00 to 21:00 Hrs	Gala Dinner with Cultural Program <i>Dinner at Qutb Shahi Tombs</i>

Day 3: Sunday, 29th January 2023	
Time	Program
6:30 Hrs	Breakfast at respective hotels
8:30 to 9:00 Hrs	Delegates arrive at the Venue: Taj Krishna Palace
9:00 to 9:15 Hrs	Welcome Address and Recap <i>At the Grand Ball Room</i>
9:15 to 10:45 Hrs	Plenary Session III: Country Allocation and Discussion on Task Force Alignment
10:45 to 11:00 Hrs	Tea / Coffee Break <i>At the Grand Ball Room (pre function area)</i>
11:00 to 13:15 Hrs	Plenary Session IV: Country Opportunity: Startup Ecosystem
13:15 to 13:30 Hrs	Concluding Remarks
13:30 to 14:30 Hrs	Networking Lunch <i>At the GBR Lawns</i>
16:15 to 16:30 Hrs	Gathering at main lobby for departure for Excursion Tour
17:15 to 18:30 Hrs	#IncredibleIndia: Hyderabad Chapter <i>Golconda Tour and Light & Sound show</i>
19:30 Hrs onwards	Dinner with Cultural show <i>At Chowmahalla Palace</i>

Day 4: Monday, 30th January 2023	
Time	Program
6:30 Hrs	Breakfast at respective hotels
10:00 Hrs onwards	Delegates check-out and depart for the Airport

Side Events	
Time	Program
16:00 to 19:00 Hrs (28th January 2023)	Innovations of India: Startup Exhibition
14:30 to 15:30 Hrs (29th January 2023)	Closed Door Session on Startup20 and Task Forces <i>(Exclusively for HoDs of international delegation only)</i> <i>At the Garden Room, Taj Krishna</i>

General Note:

- It may be noted that all meetings / events of the Start Up 20 Inception Meeting will take place in hotels located in and around the perimeter of the Hotel Taj Krishna

3. ACCREDITATION OF PARTICIPANTS

वसुधैव कुटुम्बकम्

ONE EARTH • ONE FAMILY • ONE FUTURE

All delegates attending the Startup20 Inception at Hyderabad must be registered and accredited.

Overseas Delegation Contact Officer (DCO)

Each delegation is requested to appoint a Delegation Contact Officer (DCO). The DCO should be present at the meeting and will be the first point of contact for the Startup20 team for any administrative or logistical support needed by the delegation. All DCO's are requested to register by emailing the following details to startup20.g20@investindia.org.in and **share all the below details latest by 30th December 2023.**

Name of DCO:

Email ID of DCO:

Phone Number of DCO:

Details of Incoming Delegation:

S.No	Name of the Delegate	Designation	Organization name	Country	Email ID	Phone Number
1						
2						
3						
4						

Upon receipt of the above details, a **registration link** will be sent to DCO to update the itinerary, VISA and booking details of the incoming registration to **accredit the delegation formally**. The registration on the link is mandatory and the last date to update all necessary information would be **5th January 2023.**

Delegation Liaison Officer (DLO)

A delegation liaison officer (DLO) from the Startup20 Secretariat will be assigned to each delegation for the duration of the meeting. The DLO will welcome the delegation and accompanying delegates upon arrival at the airport and assist them upon departure. The DLO will also collect the delegation kits, passes and badges in advance of the meeting and hand it over to the delegation members. DLOs will make initial contact with each delegation's DCO. DLOs contact details will be shared with each delegation prior to the meeting.

4. MEDIA & COMMUNICATION

वसुधैव कुटुम्बकम्

ONE EARTH • ONE FAMILY • ONE FUTURE

The proceedings of the G20 Meetings are confidential; as such media coverage of G20 meeting proceedings is prohibited.

However, accredited media will be allowed outside the meeting venue. Information regarding media accreditation will be sent separately.

The Indian Presidency will publish the official documentation and statements on the G20 Official platforms which include:

Official G20 Startup20 Channels:

- Website: www.startup20india2023.org
- Twitter: @Startup20org
- Instagram: @Startup20org
- LinkedIn: @Startup20org
- Facebook: @Startup20org
- YouTube: @Startup20org
- Koo: @Startup20org

5. VISA REQUIREMENTS

वसुधैव कुटुम्बकम्

ONE EARTH • ONE FAMILY • ONE FUTURE

The Government of India has bilateral Visa Exemption Agreements for holders of Diplomatic/ Official/Service Passports with a number of countries. The details can be found at <https://mea.gov.in/bywa.htm>. Diplomatic & Official Passport holders of exempted countries are not required to apply/obtain visa.

All other registered delegates (from countries which do not have a bilateral visa exemption agreement for holders of Diplomatic/Official/Service Passports) intending to travel using Diplomatic/Official/Service Passports will be issued Diplomatic & Official Visa with multiple entries, to attend the event which will be made available on the basis of confirmed registration of the delegate. Once the accreditation is complete, delegates can submit the printout of the confirmation along with the visa form to the concerned Indian Mission or Consulate, for affixing the appropriate Indian visa. In such cases application for diplomatic/official Visas may be made at Government of India's website <https://indianvisaonline.gov.in>. It may be noted that e-Visa is not available on Diplomatic / Official Passports.

Delegates travelling with an ordinary passport are also requested to apply for either multiple entry Conference Visa or Business Visa (Regular/Paper visa) from the Indian Missions or Consulates accredited in the respective countries of residence or nearest Indian Missions or Consulates. Ordinary passport holders can also apply multiple entry e-Conference or e-business visa (electronic visa) at <https://indianvisaonline.gov.in> (list of eligible countries for e-visa can be found at <https://indianvisaonline.gov.in/evisa/tvoa.html>). Regular/Paper Visa or e-Visa will be issued with the endorsement "G20 Meetings/Summit" for such purpose.

Delegates from UN/ Other International Organizations holding Diplomatic/Official Passports or United Nations Laissez-Passer may apply to the nearest Indian Mission for getting the appropriate Visa. It may be noted that e-Visa facility is not available for those holding international travel document like UN Passport.

All delegates to ensure that their passports have at least six months validity and minimum of two blank passport pages for validation.

6. HEALTH REQUIREMENTS

वसुधैव कुटुम्बकम्

ONE EARTH • ONE FAMILY • ONE FUTURE

Guidelines for International Arrivals into India:

All incoming delegates/officials shall be subject to Ministry of Health and Family Welfare (MOHFW) Guidelines for International Arrivals.

The latest guidelines are available at:

<https://www.mohfw.gov.in/pdf/GuidelinesforInternationalarrivalsupdatedon02September2022.pdf>

Delegates are advised to refer to the link of MOHFW to stay abreast of any changes to the health protocols.

Other vaccinations

- Any person arriving in India by air within 6 days of departure / transit from a yellow fever endemic area must possess a yellow fever vaccination certificate.

During the Meeting

- Delegates are encouraged to wear a mask both indoors and outdoors, to regularly sanitize their hands, and to maintain physical distance as far as possible.
- Delegates are requested to self-monitor their health and to report any illness at the earliest to the Medical Unit at the hotel/meeting venue.

- Health facilities including a dedicated medical team will be available at all meeting venues, with ambulance services available for transport to an appropriate health facility, if required.

COVID-19 Guidelines for International Departures from India:

- There is no health check requirement by the Indian Government for passengers departing India.
- However, the Indian G20 Secretariat will facilitate a free Antigen / PCR test to help delegates in obtaining adequate health documents for their return flights. The Antigen / PCR test result will be made available within 24 hours from the collection of the sample.

7. MEETING VENUE

वसुधैव कुटुम्बकम्

ONE EARTH • ONE FAMILY • ONE FUTURE

Venue Address

Hotel Taj Krishna, Hyderabad

Website: <https://www.tajhotels.com/en-in/taj/taj-krishna-hyderabad/>

Information Center

The G20 Hospitality desk is located at the meeting venue to assist the delegates with G20 related inquiries.

Access to Venue

All delegates will be required to pass through a security screening prior to entering the venue.

Access to the venue will be restricted to the accredited delegates only who will be required to keep their badges (access card and/or pin) on display at all times during the events.

The badge carries personal information such as photograph, name, country / institution, and is non-transferable.

Bilateral Meeting Rooms

Bilateral meeting rooms at the Taj Krishna with varying seating capacities will be available to delegates upon request and will be available on 28th and 29th January 2023.



Rooms will be assigned on a first come, first served basis.

Requests for bilateral meeting rooms can be made by sending an email with the date, time and participation list to shibu.nair@tajhotels.com on or before 25th January 2023. Requests can also be made directly to the Delegation Liaison Officer (DLO) upon arrival in Hyderabad.

Delegations should ensure that the meeting request clearly mentions the total number of delegates for the meeting so that appropriate space and seating requirements can be provided.

The G20 Secretariat will do its best to facilitate on-site requests for bilateral meeting rooms.

Interpretation

All meetings will be conducted in English. No interpretation services will be available.

Business Center

There will be a business center available at the meeting venue with limited number of internet-enabled computers, printing and photocopying facilities.

Wireless Internet

Complimentary wireless internet will be available at the venue for the duration of the meeting. Wireless internet access details will be available from the G20 Information Help Desk and the Business Center.

Prayer Room

Prayer Room provision for delegates will be made available at the main hotel during the course of the meeting. Signage to the Prayer Room would be displayed at the venue and, if required, assistance may be sought from the Helpdesk.

Medical Room

A medical room will remain operational at the main hotel on 28th and 29th January 2023 from 0900 to 1500 IST.



8. ACCOMMODATION

वसुधैव कुटुम्बकम्

ONE EARTH • ONE FAMILY • ONE FUTURE

The G20 Secretariat has designated three hotels as mentioned below for accommodating the delegates for the First Sherpa Meeting.

Block reservations have been made at the three hotels and delegations may book the rooms directly with the hotels on a first come, first serve basis, until **05th January 2023**, after which, the hotels will release the blocked rooms for open booking.

Contact: Shibu Nair
shibu.nair@tajhotels.com
9619347023

Taj Krishna, Hyderabad

<https://be.synxis.com/?adult=1&arrive=2023-01-27&chain=21305&child=0&config=NoPublicRates&configcode=NoPublicRates¤cy=INR&depart=2023-01-30&group=MEAG20&hotel=75714&level=hotel&locale=en-US&rooms=1>

Taj Deccan, Hyderabad

<https://be.synxis.com/?adult=1&arrive=2023-01-27&chain=21305&child=0&config=NoPublicRates&configcode=NoPublicRates¤cy=INR&depart=2023-01-30&group=MEAG20&hotel=75708&level=hotel&locale=en-US&rooms=1>

Park Hyatt Hyderabad Hotel and Residences

https://www.hyatt.com/en-US/hotel/india/park-hyatt-hyderabad/hydph?corp_id=G-MEA1
You can also email with subject line "G20: Startup20 Meeting" to Aditya Bhardwaj for any queries on aditya.bhardwaj@hyatt.com

To ensure availability of rooms for all delegations at the designated hotels, it is advised that each delegation limit its size to a **maximum of four**.

Please be advised that **all accommodation costs will be borne by the delegates themselves**.

The occupancy level of the hotels in Hyderabad may increase as we get closer to the meeting date.

We strongly recommend that you to secure your booking well in advance as per the suggested timeline and submit the details on the registration portal.

Taj Krishna



Located in Banjara Hills, a prominent and central location in Hyderabad, Taj Krishna is the ideal luxury 5-star hotel for travelers to the city of Nizams! This luxury hotel offers easy access to both the old city of Hyderabad as well as its modern twin city Secunderabad, making it a perfect choice for both business and leisure travelers.

The hotel in Banjara Hills lies in the middle of over 52609 sq.m of serene greenery in the heart of Hyderabad, offering solace to the weary traveler. The well-maintained lawns can be used to while away your time in solitude or spend time with your loved ones in the midst of nature.

The calm waters of the Hussain Sagar lake are in the immediate neighborhood and are a treat to sore eyes. Shopping for luxury brands has never been easier, with a range of options (Montblanc, Canali, Bang & Olufsen, Lladro, Tod's, Burberry and Ermenegildo Zegna) in the shopping arcade within the hotel. More shopping options are only a quick drive away.

Taj Deccan



Located in Hyderabad's elite Banjara Hills, this elegant hotel offers a welcome respite for both leisure and business travellers alike. Spread over 6 acres of landscaped gardens, it is conveniently located 35-40 minutes away from the Rajiv Gandhi International Airport and 5 kilometres away from the railway station, and roughly 19 kilometres away from Secendrabad. The Hyderabad hotel has 151 comfortable and spacious rooms, including 10 suites. At Taj Deccan, they have 6 conference rooms, including one boardroom. Their meeting venues can accommodate from 15 to 500 guests.

Park Hyatt



Nestled between the prime residential neighborhoods of Jubilee Hills and Banjara Hills, Park Hyatt Hyderabad is only a 40 minute drive from the airport and 10 minutes from the CBD, 20 minutes from HICC, Hi-Tech City, and 5 minutes from the city's largest park, KBR.

9. FLIGHT INFORMATION, IMMIGRATION, AIRPORT TRANSFER, & CUSTOMS

वसुधैव कुटुम्बकम्

ONE EARTH • ONE FAMILY • ONE FUTURE

Flight Information

- a. Delegates attending the G20 Meeting should make their own travel arrangements to and from Hyderabad. The Rajiv Gandhi International Airport at Hyderabad is an international airport that serves Hyderabad, the capital of the Indian state of Telangana. It is located in Shamshabad, about 24 kilometres south of Hyderabad. The Airport is located about 30 km and approximately 40 minutes driving distance from the meeting venue. Delegates are advised to arrange flights so as to **arrive in Hyderabad on 27th January 2023** and share their arrival and departure flight details at the time of registration.

b. Immigration

The immigration process will be completed at the Rajiv Gandhi International Airport, Hyderabad in India for all delegates. A dedicated lane for immigration is available for all delegates with Diplomatic/official passports.

c. Transportation

All delegates will be provided shared transportation services between Airport and the recommended hotels upon arrival and time of departure. Transportation between the hotel and the various venues as per the programme will also be arranged by the G20 Secretariat.

d. Customs

Indian national laws govern the importation and exportation of prohibited or controlled items into or out of India, including medications. Delegates are allowed to bring medication, strictly for personal use. Drugs containing narcotics are prohibited from entering India. Those containing psychotropics are restricted and must be declared. In addition, delegates must present a letter from their physician and/or a copy of the original prescription stating the list of medication(s) and amount used per day to a customs officer. These documents are essential to prove the legality of the prescribed medication, should there be questioning by the customs officer.

The government exempts some excisable goods purchased abroad for personal use from import duties, excise, and taxes for every adult at each arrival with the following limited amount:

Item	Maximum Allowance
Alcohol	2 Liters
Cigarettes	100 Cigarettes
Cigars	25 Cigars
Tobacco	125 grams

Any excess of the excisable goods will be destroyed. Incoming delegates carrying more than USD 10,000 (or equivalent in other foreign currencies) in cash should declare the same to Customs.

Temporary licenses to carry or use firearms and communication gadgets are considered diplomatic facilities and are provided solely to the Head of State/ President's security personnel and Ministers/Governors in compliance with Indian law. The delegation may submit a request for firearms permit well in advance through a diplomatic note with the necessary documentation attached. The diplomatic note should be addressed to the Chief of Protocol, Ministry of External Affairs of the Government of India, via the respective Country's Mission in India.



10. EXCURSION

वयुधैव कुटुम्बकम्

ONE EARTH • ONE FAMILY • ONE FUTURE

Qutb Shahi Tombs



Erected in the memory of the departed kings of Golconda, they are magnificent monuments that have withstood the test of time and nature's vagaries. They are located one kilometer north of Golconda Fort's called Banjara Darwaza. They are imposing marvels of architectural excellence that stand as the reminders of the glory of Golconda kings who are buried at the same spot. Built by the Qutub Shahis, these tombs are considered to be among the oldest historical monuments of Hyderabad.

These tombs are present in a large group on a raised platform. They resemble Persian, Pathan and Hindu architectural styles that makes use of grey granite, with stucco ornamentation and is a one-of-its-kind place in the world where the whole dynasty is buried at a single spot. They lie amidst beautifully landscaped gardens with intricately carved stonework.

Chowmahalla Palace



Once the seat of the Asaf Jahi dynasty, the Chowmahalla Palace was built in Hyderabad between the years 1857 and 1869. In essence, Chowmahalla can be literally translated to mean 'Four Palaces'. The magnificent monument consists of two massive courtyards as well as a grand dining hall known as 'Khilawat'. This splendid monument that once served as the official residence of the Nizams of Hyderabad during their reign still retains some of its past splendour. It is still the property of Barkat Ali Khan Mukarram Jah, heir of the Nizams and has been decorated with UNESCO's Asia Pacific Merit award in 2010 as well.

The architecture of the Chowmahalla Palace is an imposing sight to behold. The facade itself is a delicate artwork of domes, arches, windows and meticulously carved out designs. The complex is elegantly embellished with gentle fountains, expansive lush gardens, numerous palaces, Clock Tower, Roshan Bangla and the Council Hall.

11. PERSONAL INFORMATION

वसुधैव कुटुम्बकम्

ONE EARTH • ONE FAMILY • ONE FUTURE

The Startup20 Secretariat collects personal information to facilitate registration, accommodation, liaison and logistics arrangements pertaining to the Inception meeting.

The data of the delegates will be fully protected and accessible only to a limited number of personnel of the Startup20 Secretariat under the prevailing laws and regulations of the Republic of India.

At the conclusion of the Startup20 Inception meeting, all personal data will be destroyed in a safe and secure manner.

12. GENERAL INFORMATION

वसुधैव कुटुम्बकम्

ONE EARTH • ONE FAMILY • ONE FUTURE

ABOUT HYDERABAD

Hyderabad is the capital of southern India's Telangana state. A major center for the technology industry, it's home to many upscale restaurants and shops. Its historic sites include Golconda Fort, a former diamond-trading center that was once the Qutb Shahi dynastic capital. The Charminar, a 16th-century mosque whose 4 arches support towering minarets, is an old city landmark near the long-standing Laad Bazaar.

Weather in January

[January](#), like [December](#), in [Hyderabad](#), [India](#), is another warm winter month, with an average temperature fluctuating between 28.8°C (83.8°F) and 15.2°C (59.4°F). **Temperature**

In January, the average high-temperature is essentially the same as in December - a still warm 28.8°C (83.8°F). The average low-temperature, in January, is 15.2°C (59.4°F).

DRESS CODE

Dress code for all meetings is formal business attire. Delegates are expected to wear smart casual attire or traditional Indian attire for the Welcome Reception and Dinner.

TIME ZONE

Local time in Hyderabad is India Standard Time (IST) which is **GMT+ 5 ½ hours**.

INTERNATIONAL DIAL CODES

The country code for India is +91, and the local code for Hyderabad is 040. To call a local number, you can dial +91 followed by the local code 040 and then dial the number you wish to call. Likewise, to call an Indian mobile number when calling from a foreign number, you should dial +91 followed by mobile number you wish to contact.

Delegates intending to use an Indian SIM-card can obtain the same from an authorized mobile network operator.

CURRENCY AND BANKING

The currency of India is the **Indian Rupee (INR)**. **Current exchange rates against the US Dollar are approximately 80 INR to one US Dollar.** Currency is easily exchanged at the airport and at designated Government of India approved dealers and at the designated hotels. Delegates can withdraw Rupees through ATMs. There will also be facilities for currency-exchange at the Hotels. Major foreign credit cards are accepted in all modern establishments; hotels, restaurants and stores.

ELECTRICITY

The electricity supply voltage in India is **220-240 volts with plug types C and D**. The Indian G20 Secretariat will provide a power outlet at the delegate's desk at the meeting venue. Delegates are encouraged to bring their equipment, such as electric adaptors for mobile devices intended to be used. Round pins with three points are used in Indian plug point (as shown in the pictures below).

Dimensions Guide Type C Plug & Socket

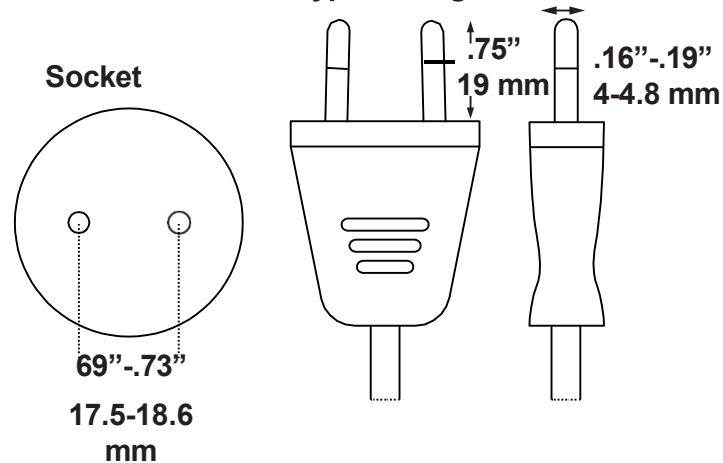

Dimensions Guide Type D Plug & Socket

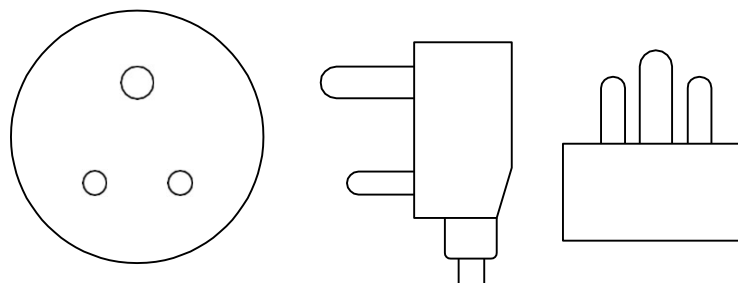

DRINKING WATER

Tap water is not potable. Delegates are advised to consume bottled water only.

EMERGENCY PHONE NUMBERS

For any urgent matters, please contact the Main Control Room located in Hotel Taj Krishna, Hyderabad. You may also call the Emergency Numbers as tabulated below.

Police	Fire	Ambulance	Central Helpline Number
100	101	108 / 102	112

FIRST AID

An emergency medical support unit will be available at each of the hotels at all times and in the meeting venue during the meetings.

ACCESSIBILITY AND SPECIAL REQUIREMENTS

Delegates are encouraged to inform the Indian G20 Secretariat on any special needs requiring assistance, such as accessibility and ambulatory requirements, special dietary preferences, allergies, medical issues and any other needs through email at g20.logistics@gov.in latest by **20th Jan 2022**. All information will be treated confidentially.

PHOTOGRAPHY

Delegates and participants may be filmed or photographed by the Indian G20 Secretariat's official photographers/broadcasters over the course of the programme. In addition, photographs and short video compilations of the Startup20 Inception would be available on the G20 official website following the conclusion of the event and would also be used in the official social media posts of the G20 Presidency.

13. IMPORTANT DATES

वसुधैव कुटुम्बकम्

ONE EARTH • ONE FAMILY • ONE FUTURE

No	Description	Date
1	Last date for registration of delegates	05 th January 2023
2	Last date for update of hotel reservation, flight details of delegates on the website and other special requirements	08 th January 2023
3	Arrival in Hyderabad	27 th January 2023
4	Networking Reception	27 th January 2023
5	Main Sessions	28 th and 29 th January 2023
6	Ratri Bhoj Par Samvad (Conversation over Dinner)	28 th and 29 th January 2023
7	Excursion	28 th and 29 th January 2023
8	Departure of delegates	30 th January 2023

